

User manual

18.3.2016
V1.0-1.7

RMD680 16 channel transmitter

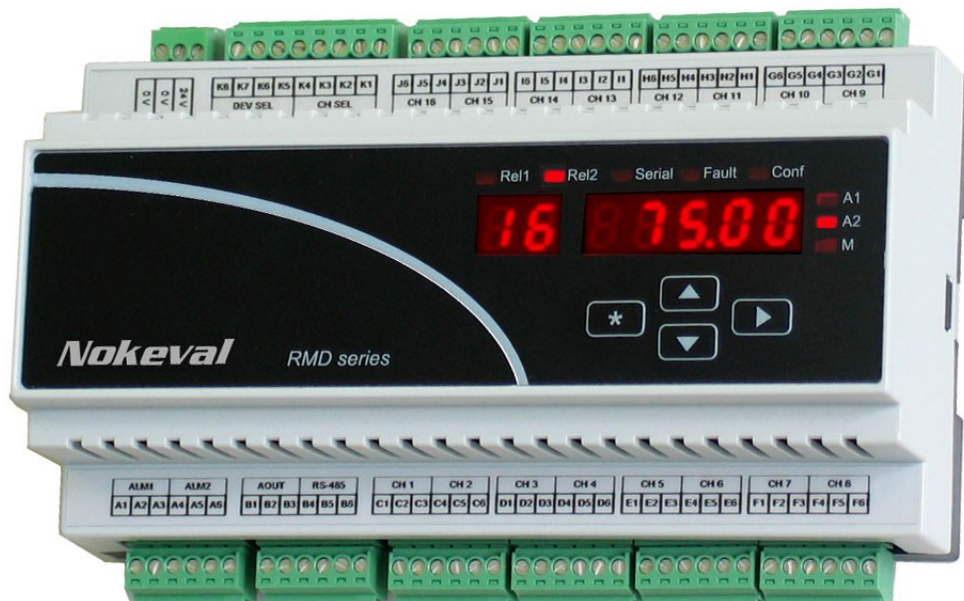

Nokeval

DESCRIPTION

RMD680 is a 16 channel measurement unit for temperature sensors and other electrical inputs. The unit has both analog and serial outputs. The analog output can be selected among the input channels using binary PNP inputs. Every channel has two alarm levels controlling two common alarm relays. The inputs are galvanically isolated from the outputs and the supply voltage, but not from each other.

There is a 2+5 digit display and four push-buttons, that can be used to monitor the readings and to change the settings. The settings can also be edited from a personal computer using RS-485 serial connection. Protocols offered are Nokeval SCL and Modbus RTU.

SPECIFICATIONS

Inputs

		Ambient comp Accuracy	0.02 °C/°C 0.05% rdg + 1°C + lin.error
Pt100		mV	
Range	-200...+700 °C	Ranges	±55 and ±100 mV
Accuracy	0.05% rdg + 0.25°C	Accuracy	0.1% rdg + 0.01 mV
Thermal drift	0.02°C / °C	Load	>1 Mohm
Sensor current	0.25 mA, multiplexed		
		V	
Ni100		Ranges	1V (-1...+1 V) 2.5V (-1...+2.5 V) 10V (-10...+10 V)
Range	-60...+180 °C	Accuracy	0.05% rdg + 0.01 V
Accuracy	0.05% rdg + 0.25°C	Load	>1 Mohm
		mA	
Cu10		Range	±20 mA
Range	-200...+260 °C	Accuracy	0.008 mA
Accuracy	1°C	Load	50...80 ohm
		Ohm	
KTY83		Ranges	0...400 ohm 0...4000 ohm 0...40000 ohm
Range	-55...+175 °C		
		Common	
PtXXX, NiXXX, CuXXX		A/D conversion	16 bits (±32767)
Range	Same as Pt100, Ni100...	Speed	Cycle time is (number of channels + 1) / 12 seconds. All channels in 1.4 seconds.
		Cable length	Max 30 m (EMC)
Thermocouples		Overvolt category	Not rated; input common mode potential may not exceed 50 VAC or 120 VDC with respect to ground
	TC range		
	B 400...1700°C		±lin.error
	C 0...2300°C		±0.3°C
	D 0...2300°C		±0.5
	E -100...900°C		±1
	G 1000...2300°C		±0.2
	J -160...950°C		±2
	K -150...1370°C		±1
	L -150...900°C		±0.5
	N 0...1300°C		±0.5
	R 0...1700°C		±0.1
	S 0...1700°C		±0.5
	T -200...400°C		±0.5
			±1

Analog output

mA output

Range	0...20 mA or less
Accuracy	0.008 mA
Load	0...600 ohm

V output

Range	0...10 V or less
Accuracy	0.005 V

Common

Source	Certain channel, externally selected channel, minimum, maximum, or serial comms
Channel select time	< 40 ms

Digital inputs

Use	Selecting the input channel to be displayed or for the analog output; can be read with serial comms
Direction	PNP (active high), internal pull-downs.
Passive level	-0.5...1 V
Active level	3...30 V
Load	about 5 kohm
Cable length	Max 3 m (EMC)

Serial connection

Connection	RS-485
Protocols	Nokeval SCL Modbus RTU
Baud rates	1200, 2400, 4800, 9600, 19200, 38400, 57600
Bits	SCL: 8N1 Modbus: 8E1, 8O1, 8N2
Max response time	SCL: typ 3, max 65 ms Modbus: typ 5, max 15 ms (after changing settings, 300 ms for the next command)
Reading all chs	SCL: 110 ms @38400 baud Modbus: typ 28, max 38 ms
Min response time	3.5 characters
Termination	Jumper selectable: None or 110 ohm + 1 nF

Alarms

Response	Same as meas. cycle + definable delay
Relays	2 A, 250 VAC

Device unpowered Relay 1 closed, 2 open.

Supply voltage

Voltage	24 VDC \pm 15%
Current	< 100 mA

Environment

Oper. temperature	-10...+60 °C
Humidity	10...90 %RH non-condensing
Altitude	Max 2000 m when hazardous voltages involved; unlimited otherwise
Pollution class	1

Other

Weight	350 g
Mounting	35 mm DIN rail
Connectors	1.5 mm ² , detachable
Galvanic isolation	Inputs together. Power supply and analog and serial output together. These groups isolated from each other.

Regulations

EMC immunity EN 61326-1:2013

EM field	61000-4-3, 10 V/m: criterion A.
Burst	61000-4-4, any port, 2 kV: criterion B.
Surge	61000-4-5, power supply, 1 kV line-to-line: criterion A. 61000-4-5, inputs: not applied (short-distance wires). 61000-4-5, serial and outputs: 1 kV line-to-ground: criterion B.
Conducted RF	61000-4-6, any port, 3 V: criterion A (shielded cable used).

EMC emissions EN 61326-1:2013

RF emissions	CISPR 11:2009 class B group 1
--------------	-------------------------------

Electrical safety EN 61010:2010

INSTALLING

Connections

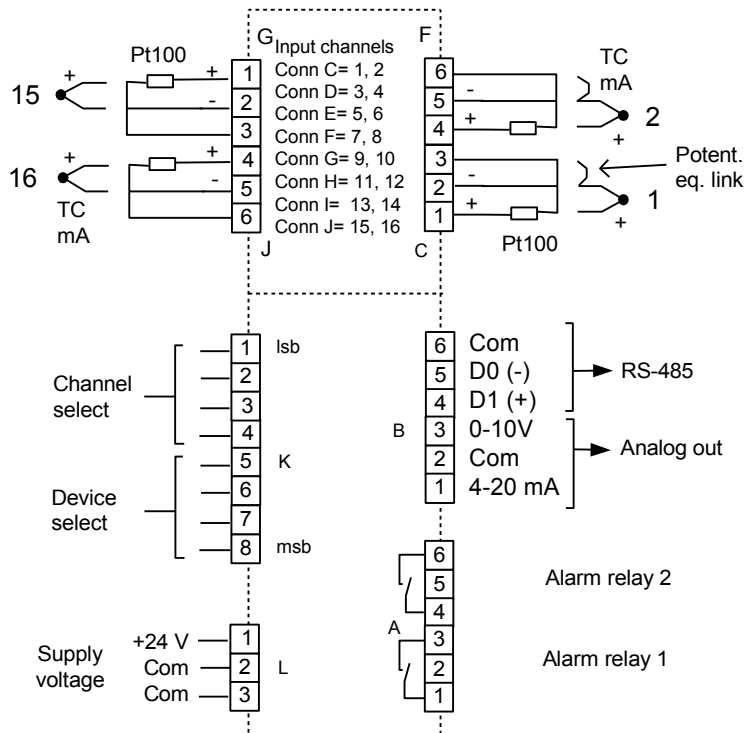

Input channels

There is three terminals for each input channel: positive and negative input and the ground. The ground connections are connected together among the channels, but the positive and negative inputs are differential and can tolerate about 1 V above or below the ground. Potential equalisation is needed to keep the input voltages near the ground. Most simple way to guarantee this is to connect the negative input to ground (2-3 and 5-6). This is not applied to resistance measurements, that use all the three terminals.

Voltage inputs

The voltage inputs (mV or V) are connected in terminals 1 and 2 (or 4 and 5). In addition to that the terminals 2-3 and 5-6 are recommended to be linked together in order to equalise the potential. The current input jumper must be open.

Current inputs

The current input (mA) is connected in terminals 1 and 2 (or 4 and 5). In addition to that the terminals

2-3 and 5-6 are recommended to be linked together in order to equalise the potential. The current input jumper must be closed inside the case near the connector.

Resistance inputs (Pt100 and others)

The negative end of the sensor is connected with two wires in terminals 2 and 3. The positive end is connected in terminal 1 with one wire. The sensors must be isolated.

Thermocouple inputs

The thermocouples are connected in terminals 1 and 2 (or 4 and 5), as in the figure. If the sensors are electrically isolated from the target, the sensor potential is recommended to be bound by linking terminals 2-3 (or 5-6). Instead, if there is several sensors connected to the same conducting target, the potential equalisation can be done with one wire connecting the target to terminal 3 or 6 at any channel.

Digital inputs

Digital PNP inputs are used to select the input channel for the analog output (or the channel that is displayed).

Analog output

Either mA or V output can be used. They can't be used at the same time (they do work but the other is very inaccurate). The analog output ground is the same as the power supply ground.

Serial connection

Serial connection RS-485 is available at connector B. Its ground is connected to the supply and analog output grounds. If the potential between serial devices is not equalized through the power network, it is recommended to connect their common terminals together with an auxiliary wire. If this potential equalisation is not possible, then it is advisable to engage the RS-485 floating jumper inside the case, see Jumpers.

D1 is the more positive terminal (Nokeval A or +). The maximum recommended distance is 1 km. The cable should be a twisted pair, wire gauge 0.5 mm minimum.

Alarm relays

The device is equipped with two relays capable to switch 250 VAC. If either of the relays is connected to a line voltage, the other must not be connected to low-voltage circuits. Relay 1 contacts are closed when no power is applied to the transmitter.

Power supply

Supply voltage 24 VDC is connected in connector L.

Jumpers

Inside the case, there is one jumper next to each input channel connector. It has to be closed when using mA input, and else open.

In the middle card, there is a jumper marked "2 wire". It should be closed when there is no potential equalisation between the RS-485 devices. E.g. Nokeval 711 serial converter has no common terminal, so this jumper should be used. Next to that, there is an AC termination jumper J6, that

should be enabled in the first and last device on the RS-485 bus. When neither of these is required, the jumper may be parked horizontally at the top pins of J5 and J6.

To access the jumpers, prise a screwdriver between the bottom and top covers near the locking tabs at the case ends.

Settings

The settings can be done with either the front panel buttons or the serial connection. Using the buttons is described in chapter User interface, and the settings in chapter Settings.

The PC software needed is called Mekuwin. It is free from Nokeval web site. To use it, you need

also a RS-485 connection to your computer. An inexpensive alternative is Nokeval DCS770 USB-to-RS485 converter. Select the same communication parameters in each end before attempting to connect. See also chapter Settings.

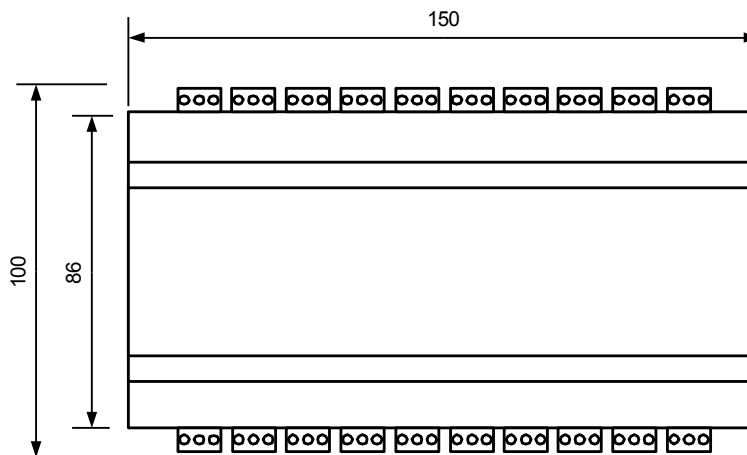

OPERATION

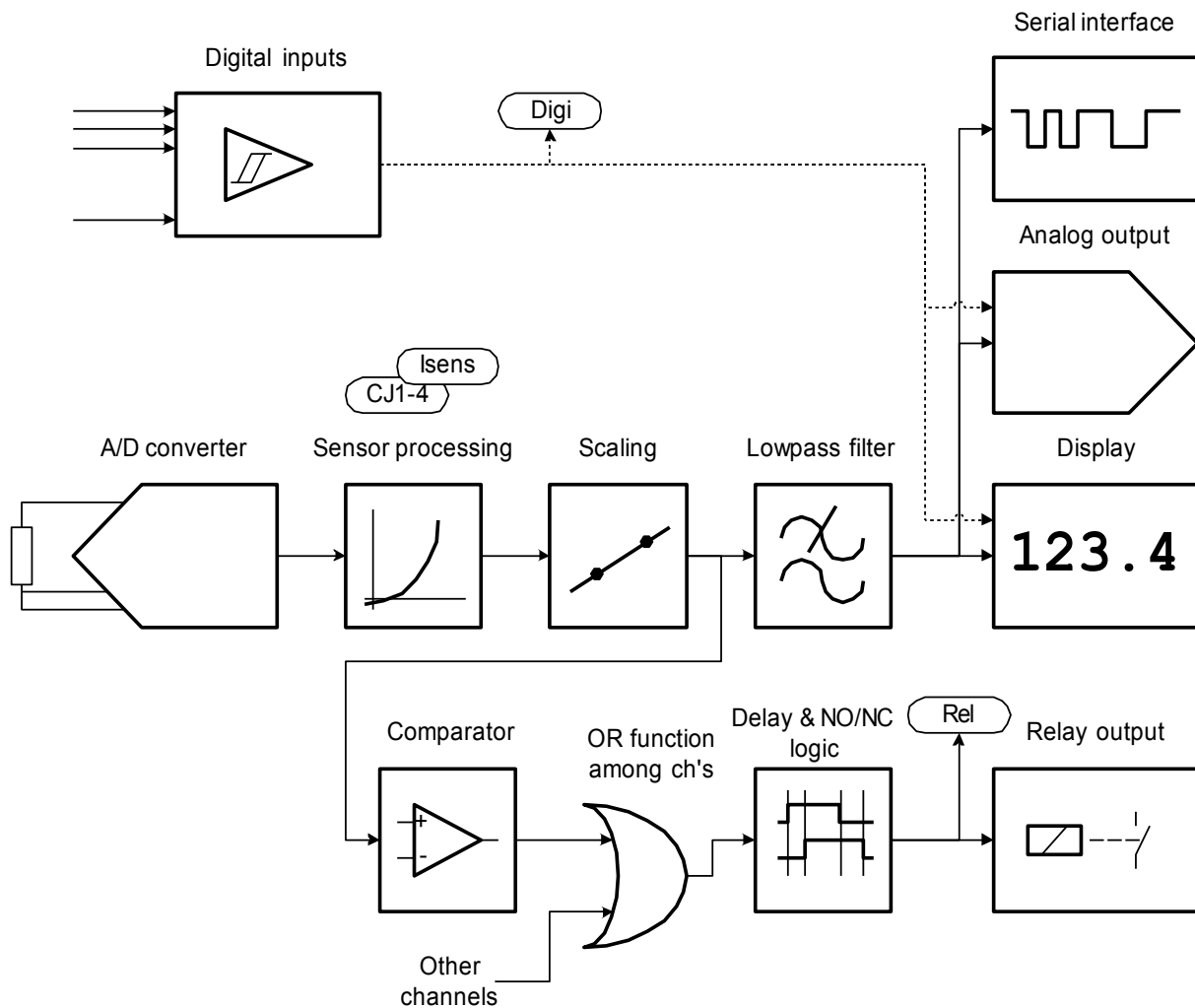

Measurement

The transmitter measures every active channel at a time. When all is done, the transmitter does one internal measurement, that means measuring the RTD sensor current or one of the four cold junction sensors. There is only one A/D converter, and it is connected to one channel at a time using semiconductor switches, along with the RTD current generators.

The A/D input is differential, measuring only the difference between the positive and negative input terminal. However these voltages must be within 1 V of the input circuit ground, which is available at

the terminals 3 and 6 at every input channel. With resistance sensors, the third wire will do it, but with the other inputs the potential equalisation should be done as described in chapter Connections. If the wires are short, it may not be necessary. See also Differential in chapter Settings.

The normal measurement speed is 12 channels per second. If there is 10 channels used, they are updated every second. Remember that there is one internal measurement in addition to the external measurements.

Analog output and digital inputs

RMD680 has one analog output. It can be selected to follow a selected input channel, or use the digital input to select the channel to be output. See Output/Source setting.

For external channel selection, the device is equipped with 8 digital inputs of PNP type. A positive voltage (3-24 V) is active state. First four terminals (K1-K4) are used to select the input channel, that is used for the analog output. When these are passive (0 V), channel 1 is used. K1 is the least significant bit.

If 16 channels is not enough, several RMD680's can be connected in parallel to one mA output. In this case, only one transmitter is activated at a time using the other digital inputs (K5-K8). When the binary word 0-15 at these terminals corresponds to the Addr setting in Output menu, the analog output is activated. There is two ways to use this:

If the terminals K1-K8 are connected in parallel in several transmitters and a different address is selected in every transmitter (Output/Addr), any

transmitter can be activated using a binary word. Maximum number of transmitters is 16.

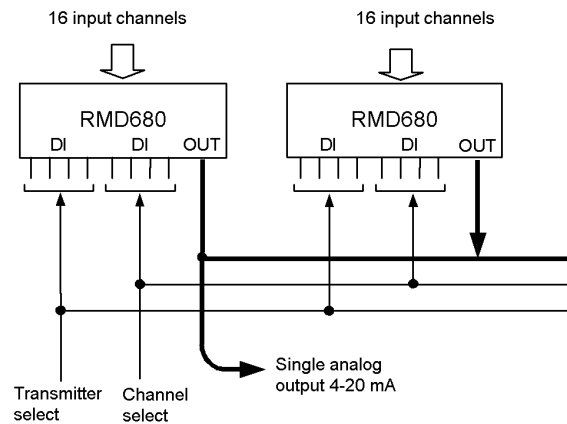

The other way is to select address 1 in every transmitter and connect a enable line to every transmitter connector K5. Bringing a voltage to this terminal activates the output.

Alarms

Every channel has two alarms, and they can be either low or high level alarms. Alarms 1 operates relay 1 and alarm 2 relay 2. If any channel has an alarm active, the corresponding relay will activate.

These channel alarms simply judge, whether the reading is above or below the alarm level. The A1 and A2 indicators on the display indicate the states on the channel being viewed. The alarms are taken from unfiltered reading. This is because the lowpass filter could work against the delay functions: a short but large input disturbance would

make the lowpass filter to give wrong, decaying reading for a long time, causing a false alarm.

The alarm information from each channel is combined using "OR logic", meaning that the common alarm will be considered active, if the alarm is active on any channel. Before applying to the relay, the activation and deactivation delays are added and the polarity reversed, if NC operation is enabled. The Rel item in Monitor menu shows the real relay state (1=pulling).

Serial connection

Serial command is received, then it is processed and finally a response is sent. To process a command and to form a response, takes typically 3, maximum 15 ms on SCL protocol, except MEA SCAN can take up to 65 ms. The whole process for MEA SCAN 1 16 takes abt 220 ms @9600 baud and 110 ms @38400 baud.

Modbus protocol is faster, since there is no need to format the readings to be human-readable. So the response time is typically 5 ms, maximum 15 ms. Reading all the inputs using Read Input Registers takes abt 100 ms @9600 baud and 30 ms @38400 baud.

USER INTERFACE

Front panel

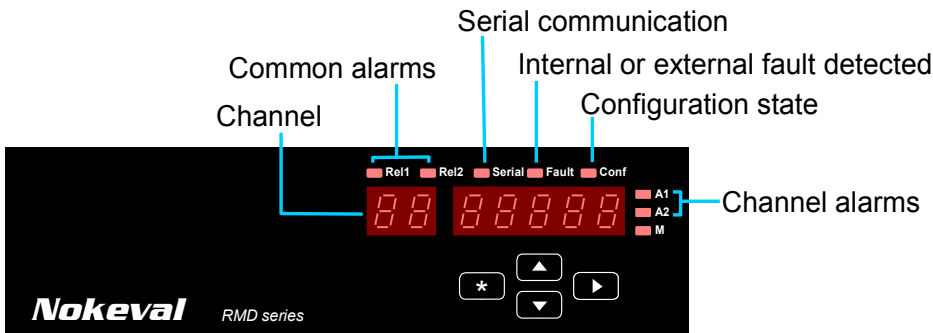

Normal state

After the power-up a channel number and a reading is displayed. Depending on the Scan setting, a fixed channel is displayed, or the channels are scanned. The channel can be selected manually using ▲▼ buttons, and after the last channel the minimum, maximum, and the average reading is displayed.

Rel1 and Rel2 indicators show the real state of the alarms: active or not active. Serial indicator is lit

when a serial message is received at correct address. Fault indicator is lit when a sensor is broken or there is internal fault. Conf is lit when in configuration state. These indicators are not dependent on the channel selected.

A1 and A2 indicate, whether there is active alarms at the selected channel. They blink when an alarm level is shown in operator menu. M is not used.

Operator menu

The alarm levels can be changed without entering the configuration state. Use ▶ button to select the function: Alarm level 1 – Alarm level 2 – Normal state. Blinking A1 or A2 indicates that an alarm level is displayed. In this state, the level can be changed by pressing first ▲ or ▼ and then ▲▼▶. When done, push *.

If common alarm level is used among the channels (Alarms / Cmn levels), the channel display will show Co (=Common) when an alarm level is displayed.

If an automatic display scan mode is used (General/Scan), it has to be interrupted temporarily. Just push ▲ or ▼.

Configuration state

Press * and ▲ simultaneously two seconds to enter the configuration state. When entered, the Conf led will light. If configuration password is set, you will need to enter it (Cod.0 displayed).

comes on, quickly press * and ▶ keys – PWDC is displayed briefly. This will also set the serial settings to their default values.

In case the password is not known, switch the power off and then on again, and when the display

The main level of the configuration menu is shown. You can select among menu items using ▲▼ keys. To edit the setting, push ▶ to start editing, and * to

get back to the menu. How to edit, see section Editing.

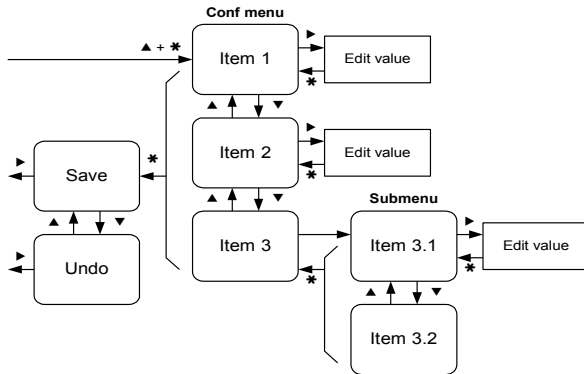

The menu is organized hierarchically. You can enter General, Input, Output, Alarms, and Serial submenus by selecting them with ▲▼ keys, and entering the submenu with ► key. See the menu chart in chapter Settings.

When all settings are done, exit from the menu with * key. Two options are shown: Save to keep the settings made, and Undo, to discard all changes. Select Save or Undo and push ►.

Editing

Most data types are edited with simply ▲▼ keys, finally exiting with * key.

Floating point values, such as scaling and the lopass filter, are edited with ▲▼► keys: select digit to edit (blinking) with ► and change it with ▲▼. When the decimal point is blinking, it can be moved with ▲▼. The first digit can be replaced with a minus sign.

To set a **password**, push ▲ to select Set (means password will be used), then push ► to enter the new password. Cod.0 is shown. The password is a sequence of six keypresses using all the four keys. Enter the same password twice; if they match, Set is shown again and you can exit with *. If they didn't match, Off is shown. Redo from start. To disable a password, push ▼ to select Off and exit with *.

Monitoring state

Monitoring can be used to examine some internal readings. Use the monitor mode in the PC software or the built-in monitor mode.

The built-in monitoring is started by pressing * and ▼ together. Select the item using ▲▼ keys, and exit with *.

Items

- **In1-In16**: latest readings.
- **Min, Max**: minimum and maximum reading on channels 1-16.
- **Avg**: average of the channels.
- **Ext**: "ext" channel controlled by serial communications; see Out\Source
- **Isens**: measured resistance sensor measurement current, normally about 0.25 mA.

- **CJ1-CJ4**: internal cold junction temperatures.
- **Digi inputs**: digital inputs as an integer 0-255.
- **Out**: analog output value mA or V.
- **Rel**: alarm relays 0=none, 1=Rel1, 2=Rel2, 3=both active.
- **Cycle time**: measurement cycle time in seconds.

Last item is **Diag**, that can be used to see diagnostic messages. Push ►. If nothing happens, then there is no messages. If happens, try ▲▼ to see if there is several messages. Exit with *.

RMD680 has two messages:

- **Sensor Fault**: some channel has improper connection, overranging, or a broken sensor or wires.

- **AD Error:** A/D converter is not working. If the supply voltage is sufficient, the device needs service.

SETTINGS

General submenu

General submenu has settings that do not belong to the other groups.

Scan

Automatic changing of the displayed channel.

- **Off:** The channel is changed only manually using buttons ▲▼.
- **All:** All the active channels are scanned, at one second interval.
- **Alarming:** Like All, but if any channel has active alarm, only alarming channels are scanned.
- **Mux:** The channel to be displayed is selected using digital inputs K1-K4, like the analog output. If the Output/Source setting is set to Mux, the Output/Addr must correspond to the digital input at K5-K8, otherwise dashes "--" are shown in the channel display and the reading display is empty..

The scanning can be always stopped temporarily by pushing ▲ or ▼ in the normal state. Then the channels can be selected manually using ▲▼ buttons and alarm levels viewed using ► button. Automatic scanning is activated again if the buttons are not touched for 10 seconds, or ▲ and ▼ are pushed together.

CfCode

Selecting password for the settings. If enabled, the configuration menu can not be entered anymore without knowing the password. How to enter the password using the front panel, see chapter User interface.

Input submenu

Input submenu contains the input settings. It is further divided in Common and Ch1-Ch16 submenus.

Input/Common submenu

Speed

Measurement speed selection. Speed 1 is intended for normal use, and the specifications are valid for that. The higher speeds will increase noise.

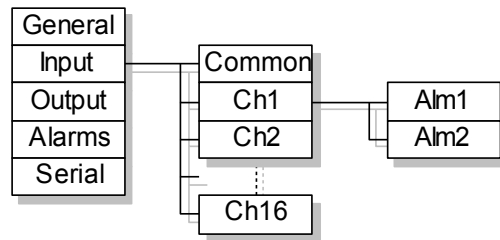

Differential

Internal grounding of the differential inputs. Not applicable to resistance inputs, like Pt100.

- **No:** The transmitter uses a semiconductor switch to ground the negative terminal of the channel being measured.
- **Yes:** The inputs are differential (or floating) and the potential equalisation must be done externally.

Pullup

Sensor/wire break sensing. If enabled, a weak current is fed to thermocouple sensors to detect breaks.

Input/Ch1-Ch16 submenus

Sensor

Input range and sensor selection.

- **Off:** Channel not used. It is recommended to set unused channels off, in order to speed up the measurement cycle.
- **55mV, 100mV, 1V, 2.5V, and 10V:** Voltage inputs. Can measure also negative voltage, however 2.5V range reaches only -1 V. The reading is in millivolts or volts according to the name of the range.
- **20mA and 50mA:** Current inputs. Can measure also negative current. The jumper inside the case has to be closed.
- **400ohm, 4000ohm, and 40000ohm:** Resistance inputs. The resistor is connected in three-wire connection. The reading in ohms.
- **Pt, Ni, Cu, and KTY83:** Resistance thermometers (RTD's). The nominal resistance is set in R0 (see below). The reading is in celsius.
- **TcB-TcT:** Thermocouples. The result is in celsius.

R0

The nominal resistance of a resistive temperature sensor. With Pt and Ni sensors, this is the resistance at 0°C, e.g. Pt100 R0=100. With Cu and

KTY83, the nominal resistance is given at 25°C. If the real resistance of the sensor at the nominal temperature is known, it can be fed here, in order to cancel the sensor error.

Lopass

First-order lowpass filter for the reading. Will attenuate noise and disturbances. Set time constant (to 63% of step change) in seconds, or 0 to disable.

Dec

The number of digits after the decimal point to be displayed. Can be set negative, to round the corresponding number of last digits to zero. In addition, this defines the decimal point location to the Modbus 16 bit integer readings (input regs 1000-1015). Examples how 123.45678 is rounded:
Dec=2: "123.45"
Dec=0: "123"
Dec=-2: "100"

Pts

Number of scaling points. The scaling means converting the reading to represent some other (engineering) reading. The scaled value is used on the display, serial output, analog output, and alarms.

- **0**: No scaling.
- **1**: One point offset correction. The reading corresponding to Mea1 is scaled to be Sca1 when displayed, using appropriate offset value.
- **2**: Two point scaling. Readings from Mea1 to Mea2 are scaled to be Sca1 to Sca2 on the display. Any values can be used, these have not to be the end points.

Mea1, Sca1, Mea2, and Sca2

Scaling points. Visibility of these settings depend on the Pts setting. Unscaled reading Mea1 is converted to Sca1, and Mea2 to Sca2.

Alm1 and Alm2

Submenus for alarm settings on each channel.

Input/Ch1/Alm submenus

Every input channel has two alarm functions. They are configured in submenus Alm1 and Alm2 below each input channel settings. Some more settings concerning the alarms are in the Alarms submenu in the Conf main level.

Type

Alarm type:

- **Off**: Alarm not used.

- **Lo**: Low level alarm. The alarm is activated when the scaled reading on this channel goes below the alarm level.
- **Hi**: High level alarm.

Level

Alarm level. If the Cmn Levels setting in Alarms submenu is on, these channel-specific level settings are hidden and replaced with one common setting in Alarms submenu.

There is no hysteresis function in the alarms. It is replaced with user-selectable delays, see Alarms menu.

Output submenu

Analog output settings.

Source

Where the output is taken from:

- **Mux**: Multiplexing, selecting the channel using the digital PNP inputs.
- **Single**: Fixed channel, see Ch below.
- **Min**: Minimum reading among input channels 1-16.
- **Max**: Maximum reading.
- **Avg**: Average reading.
- **Ext**: Ext channel, controlled by serial communications (SCL OUT or Modbus Holding 2000).

Ch

Fixed input channel selection. Visible only when Source=Single. Select input channel 1-16, that is used to control the analog output.

Addr

Multiplexing address. Visible only when Source=Mux. Select address 0-15. The analog output is active only when the digital inputs K5-K8 are controlled to correspond to this address.

Range

Analog output range mA or V.

Rdg1, Out1, Rdg2, and Out2

Output scaling. Reading Rdg1 on display corresponds to output signal Out1 (in mA or V), and Rdg2 to Out2. These have not to be the end points, since the transmitter is able to extrapolate.

Alarms submenu

Common settings of the alarms.

Cmn levels

- **No:** Every channel has alarm limits of its own (e.g. Input/Ch1/Alm1/Level).
- **Yes:** Common alarm levels are used on all channels. The levels are defined in this menu, items Lev1 and Lev2. However the alarms has to be switched on on every channel separately.

Lev1, Lev2

Common alarm levels when Cmn levels is enabled.

ActDelay, DeaDelay

Alarm activation and deactivation delays. An alarm must be continuously active for the time specified in ActDelay in order to cause a real, common alarm. The functional diagram in chapter Operation clarifies this.

The delay times are given in seconds. The maximum delay time is 3495 seconds. Note that the alarm is taken from unfiltered reading, so these delays are the only protection against false alarms.

NC1, NC2

Inverting the relay operation. Affects only the coils of the relays, but not the LED indicators.

- **No:** Normal operation, normally open: the relay pulls when an alarm is active.
- **Yes:** Inverse operation, normally closed: the relay releases when an alarm is active.

Serial submenu

Serial connection settings. Note that the changes here do not affect until the configuration state is exit.

Protocol

Serial protocol:

- **SCL:** Nokeval SCL protocol. The description of this protocol can be obtained from Nokeval www pages, and the commands are listed in chapter SCL protocol.
- **Modbus:** Modbus RTU protocol. The registers and data representation are described in chapter Modbus protocol.

Address

Serial bus address. Valid choices for SCL are 0-123 and for Modbus 1-247.

Baud

Baud rate selection. Options 1200, 2400, 4800, 9600, 19200, 38400, and 57600 bits per second.

Bits

Parity and stop bits. Visible with Modbus only; SCL uses always 8N1.

Options 8E1 (recommended), 8O1, 8N2.

SCL PROTOCOL

A more detailed description of the Nokeval SCL protocol can be downloaded from Nokeval www pages <http://www.nokeval.com/> under the data acquisition pages.

RMD680 understands the following SCL commands:

TYPE ?

Returns the model name and software version "RMD680 V1.7" without the quotation marks.

SN ?

Returns the serial number, e.g. "A123456".

MEA CH 1 ?

Returns the scaled reading on channel 1.

Channels 1-16 can be read this way. Moreover:

- channels 17 and 18 = minimum ja maximum
- channels 19 and 20 = average and Ext
- channels 22..25 = cold junction temperatures

The response consists of characters -.0123456789. The scientific notation (1E3) is not used. In case of invalid reading, the response consists of dashes "-----". With over/underflow, the response is "^^^^^" or "uuuuu".

The reading is always represented with six significant digits (except negative readings with five), e.g. pi would be represented "3.14159".

After power-up, before the first reading is obtained, the transmitter will return NAK 0 message to MEA commands, in order to prevent logger software from logging invalid readings.

MEA SCAN 1 16

Returns the readings on channels 1-16 separated by one space. See MEA CH for data representation.

OUT CH 1 23.45

Writes to the "Ext" channel a value of 23.45. The analog output can be set to follow the Ext channel by selecting Out/Source=Ext.

DI CH 1 ?

Returns the state of the digital input 1 (connector K1). The answer is either "0" or "1" without the quotation marks.

DI SCAN 1 8

Returns the states of the digital inputs separated with a space, e.g. "1 1 0 0 1 1 1 1". The digital input K1 is returned first.

MN xxxxx

Commands used by Mekuwin configuration software.

MODBUS PROTOCOL

Supported commands:

- **2 Read Discrete Inputs:** reading the digital inputs.
- **3 Read Holding Registers:** reading the settings.
- **4 Read Input Registers:** reading the input readings.
- **6 Write Single Register:** changing the settings and the Ext channel.
- **16 Write Multiple registers:** changing the settings.
- **17 Report Slave ID:** checking the device type.
- **109 Meku:** Mekuwin configuration software uses this.

When the settings are changed by writing to a Holding register, the settings are changed to the

non-volatile EEPROM memory immediately. It might take several dozens of milliseconds for the transmitter to respond to the next command.

The maximum length of the command is 150 bytes. The maximum length of the response is the same. This sets the limit to number of registers with commands 3, 4, and 16.

The command 17 will return 0x11 <byte count> 0x00 0xFF, followed with "RMD680 V1.5 A123456", for example.

When the serial connection settings are changed, the changes do not affect until the transmitter is powered down. This is to prevent breaking the connection while making the changes.

Data types

- **BOOL:** Off/on setting. Only the least significant bit is used.
- **BYTE:** One byte setting. Only the lower word of the Modbus register is used.
- **WORD:** 16-bit setting.
- **ENUM:** Option list setting. The options listed in section Enum tables.
- **CODE:** Password 12 bits. 0=not used.
- **FLOAT:** 32-bit floating point number IEEE 754. Least significant word first (LSWF, little-endian) except input registers 2000-2055 are most significant word first (MSWF).

Within one Modbus register, the data is represented always the most significant byte first (MSBF, big-endian).

Input registers

Register	Integer	Name	Type	Values
0..1	1000	In1	FLOAT	Signed
2..3	1001	In2	FLOAT	Signed
4..5	1002	In3	FLOAT	Signed
6..7	1003	In4	FLOAT	Signed
8..9	1004	In5	FLOAT	Signed
10..11	1005	In6	FLOAT	Signed
12..13	1006	In7	FLOAT	Signed
14..15	1007	In8	FLOAT	Signed
16..17	1008	In9	FLOAT	Signed
18..19	1009	In10	FLOAT	Signed
20..21	1010	In11	FLOAT	Signed
22..23	1011	In12	FLOAT	Signed
24..25	1012	In13	FLOAT	Signed
26..27	1013	In14	FLOAT	Signed

28..29	1014	In15	FLOAT	Signed
30..31	1015	In16	FLOAT	Signed
32..33		Min	FLOAT	Signed
34..35		Max	FLOAT	Signed
36..37		Avg	FLOAT	Signed
38..39		Ext	FLOAT	Signed
40..41		Isens	FLOAT	Unsigned
42..43		CJ1	FLOAT	Signed
44..45		CJ2	FLOAT	Signed
46..47		CJ3	FLOAT	Signed
48..49		CJ4	FLOAT	Signed

The channel 1-16 **readings** can also be read as 16-bit signed **integers** in registers 1000-1015. The readings have as many digits after the decimal points as is set with the Dec setting in the settings of that channel. E.g. Dec=1: divide the integer by 10 ($=10^1$) to get the reading.

For devices requiring MSWF floating point representation, the input registers are provided in that format beginning from 2000, e.g. 2000..2001 is In1 and 2002..2003 is In2, etc. Other than floating-point values should not be read at this address range.

Holding registers

The registers 0..1999 contain the configuration settings. Register pair 2000..2001 is the Ext register that can be used to control the analog output. The input readings may be accessed in Holding registers 5000 onwards, although using Input registers is recommended.

Register	Name	Type	Values
0	Conf\General\Scan	ENUM	See table E1
1	Conf\General\CfCode	CODE	
2	Conf\Input\Common\Speed	ENUM	See table E2
3	Conf\Input\Common\Differential	BOOL	
4	Conf\Input\Common\Pullup	BOOL	
5	Conf\Input\Ch1\Sensor	ENUM	See table E3
6..7	Conf\Input\Ch1\R0	FLOAT	Unsigned
8..9	Conf\Input\Ch1\Lopass	FLOAT	Unsigned
10	Conf\Input\Ch1\Dec	BYTE	Signed -3..4
11	Conf\Input\Ch1\Pts	BYTE	Unsigned 0..2
12..13	Conf\Input\Ch1\Mea1	FLOAT	Signed
14..15	Conf\Input\Ch1\Sca1	FLOAT	Signed
16..17	Conf\Input\Ch1\Mea2	FLOAT	Signed
18..19	Conf\Input\Ch1\Sca2	FLOAT	Signed
20	Conf\Input\Ch1\Alm1\Type	ENUM	See table E4
21..22	Conf\Input\Ch1\Alm1\Level	FLOAT	Signed
23	Conf\Input\Ch1\Alm2\Type	ENUM	See table E4
24..25	Conf\Input\Ch1\Alm2\Level	FLOAT	Signed
26	Conf\Input\Ch2\Sensor		
	The register address of the other channels is obtained by adding $21*(Ch-1)$ to the channel 1 settings.		
341	Conf\Output\Source	ENUM	See table E5

342	Conf\Output\Ch	BYTE	Unsigned 1...16
343	Conf\Output\Addr	BYTE	Unsigned 0...15
344	Conf\Output\Range	ENUM	See table E6
345..346	Conf\Output\Rdg1	FLOAT	Signed
347..348	Conf\Output\Out1	FLOAT	Signed
349..350	Conf\Output\Rdg2	FLOAT	Signed
351..352	Conf\Output\Out2	FLOAT	Signed
353	Conf\Alarms\Cmn levels	BOOL	
354..355	Conf\Alarms\Lev1	FLOAT	Signed
356..357	Conf\Alarms\Lev2	FLOAT	Signed
358..359	Conf\Alarms\ActDelay	FLOAT	Unsigned
360..361	Conf\Alarms\DeaDelay	FLOAT	Unsigned
362	Conf\Alarms\NC1	BOOL	
363	Conf\Alarms\NC2	BOOL	
364	Conf\Serial\Protocol	ENUM	See table E7
365	Conf\Serial\Address	BYTE	Unsigned 0...255
366	Conf\Serial\Baud	ENUM	See table E8
367	Conf\Serial\Bits	ENUM	See table E9
2000..2001	Ext	FLOAT	Signed
2002	Ext	WORD	Signed
5000..5055	In1...	FLOAT	
6000..6028	In1...	WORD	Signed

Discrete input registers

The discrete input registers 0-7 correspond to the digital inputs K1-K8.

Enum tables

Table E1

Value	Scan
0	Off
1	All
2	Alarming
3	Mux

Table E2

Value	Speed
0	1 normal
1	2
2	3
3	4 fastest

Table E3

Value	Sensor
0	Off
1	55mV
2	100mV
3	1V
4	2.5V
5	10V
6	20mA
7	50mA
8	400ohm
9	4000ohm
10	40000ohm
11	Pt
12	Ni
13	Cu
14	KTY83
15	TcB
16	TcC
17	TcD
18	TcE
19	TcG
20	TcJ
21	TcK
22	TcL
23	TcN
24	TcR
25	TcS
26	TcT

Table E4

Value	Type
0	Off
1	Lo
2	Hi

Table E5

Value	Source
0	Mux
1	Single
2	Min
3	Max
4	Avg
5	Ext

Table E6

Value	Range
0	mA
1	V

Table E7

Value	Protocol
0	SCL
1	Modbus

Table E8

Value	Baud
0	1200
1	2400
2	4800
3	9600
4	19200
5	38400
6	57600

Table E9

Value	Bits
0	8E1
1	8O1
2	8N2

Nokeval

**Rounionkatu 107
FI-37150 Nokia
Finland**

**Tel +358 3 3424800
www.nokeval.com**