

Manual

Model 2021

Universal Input



Contents

General Description	3
Dimensions	3
Universal input digital panelmeter 2021	3
Technical specification	4
Ordering types	4
Front panel and keys	5
Configuration	5
Reset of configuration parameters	5
Setting of alarm value	5
Setting of alarms	5
Configuration	6
Starting:	6
Configuration parameters	7
Input selection	7
Alarm functions	8
General description	8
Alarm card connections	8
Alarm settings by front panel keys	8
Selection of alarm card and relay-function settings	9
Card type	9
Main menu	9
Shifting in menu	9
Examples of alarm settings:	10
Display hold by external control (option)	10
Output 0/4..20 mA (option)	11
Output connections	11
Serial output RS-485/RS-232 (option)	12
Serial protocol (SCL)	13
Minimum and maximum value memory	14
Reset memory	14
Setting of secret codes (Programming stage/ alarms)	14
Terminal connections	15
2-wire 4-20 mA	15
Potentiometer	15
Card slots	15
Voltage 0-10V	15
Current input 0/4..20 mA	15
Thermocouples and mV	15
Pt-100 3- and 4-wire	15
Panelmeter 2000 construction	16
2000 series input and option cards:	17
Modular indicator serie 2000	17

Universal input digital panelmeter 2021

3-way galvanic isolation

24 VDC, max. 150 mA

Input

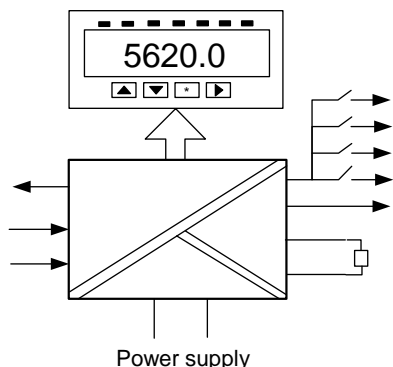

Alarms 1-4

RS-485/232

Output



6-digit display enables to show easily measurements which require large number values, f.ex. sea level height 105.000 m

General Description

Panelmeter 2021 is extremely versatile instrument. Almost all sensor inputs are programmable like thermocouples, resistance inputs, process inputs, mV and potentiometer inputs. Meter provides 24 VDC, 150 mA power for sensors.

Meter has three slots, one for inputs (obligatory) and two additional slots for output, alarms or serial signal. By changing input card you can get another instrument like pulse meter (2051) or strain gage meter (2041) etc. Changing input card changes meters model number; each meter has its own data sheet and instruction manual.

Meter program supports many additional card combinations. Furnishing the meter needs no calibration, only the sensor choices and corresponding settings has to be made by front panel keys.

Analog conversation is made by 16 bit AD converter (resolution 1/64000) display can be damped by digital filter.

Separate secret codes for entering program stage and settings of alarms. Minimum and maximum display is as standard, optional hold of display by external contact.

Two alternative power supplies, line voltage 85..240 VAC or 12..32 VDC and 24 VAC. Both are isolated from inputs and outputs. Terminal connectors are colour coded in order to avoid erroneous connections. Front panel rating is IP65.

Dimensions

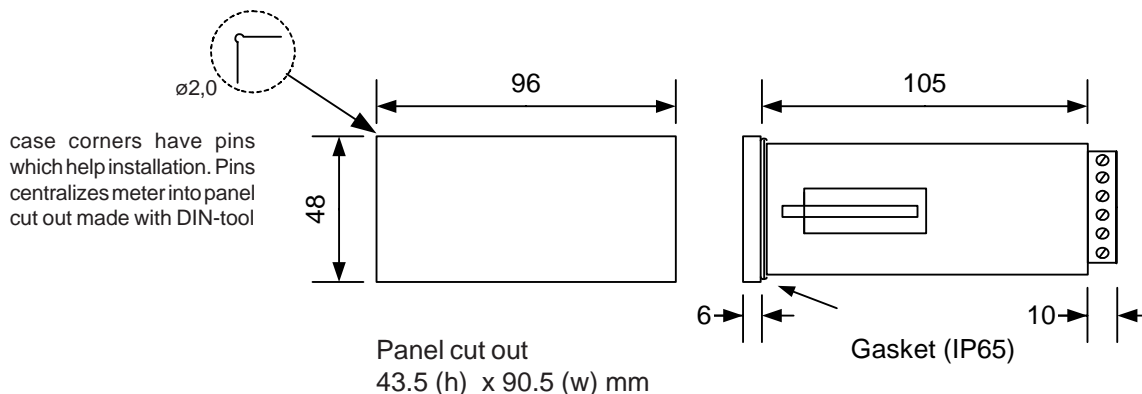

Technical specification

Process inputs:

Linear	0..20 mA, 4..20 mA, 0..10 V -10..+10 V
Squared	0..20 mA, 4..20 mA
Display scaling	On whole display range, 999999
Input resistance	current inputs 50 Ω voltage inputs 1 MΩ
Accuracy	0.02% FS
Linearity	0.005% FS
Sensor supply	24 VDC, max. 150 mA

RTD sensors:	Pt100	-200...+700°C
	Pt1000	-200...+700°C
	Ni100	-50... +170°C
Connection:	3- and 4-wire	
Measuring current	0.25 mA	
Accuracy	0.05% FS	
Linearity error	<0.05°C (-200..700°C), Pt100	

Thermocouples:

12 linearized thermocouples

TC	Whole range	Linearization error
E	-100.... 900°C	< 0.2°C -50... 900°C
J	-150.... 900°C	< 0.2°C -50... 900°C
K	-150.... 1350°C	< 0.4°C -40... 1300°C
L	-100.... 900°C	< 0.4°C -50... 900°C
T	-150... 400°C	< 0.2°C -150...400°C
N	0.... 1300°C	< 0.2°C 0.... 1300°C
R	0.... 1700°C	< 0.3°C 400... 1700°C
S	0.... 1700°C	< 0.3°C 300... 1700°C
C (W5)	0.... 2200°C	< 0.3°C 400... 2200°C
D (W3)	0.... 2200°C	< 0.3°C 500... 2200°C
B	400... 1700°C	< 0.3°C 400... 1700°C
G (W)	1000... 2200°C	< 0.4°C 1000. 1700°C

Accuracy	0.1 % of span
Compensation error	0.05°C/°C
Line resistance effect	<100 Ω, no effect
TC cut protection	Upscale

mV-inputs:	25, 55, 100, 1000, 2500 mV and 5000 mV
Accuracy	0.01% of span >100 mV 0.02% < 100 mV
Input resistance	25, 55, 100 mV: >1 MΩ 1000, 5000 mV: ≈ 800kΩ

Note! User selectable scale multiplier for max valule

Potentiometer:	0.5 kΩ, 2 wire connection
Accuracy	0.05 % FS

Output:	0..20 mA, 4..20 mA or 0..10V
max. load	650 Ω
Accuracy	0.05 % FS
Scaling	freely adjustable

Alarms:

Total	Max 4 alarm relays
2000-REL2	2 change over relays, max 230 V, 2A
2000-REL3	3 closing contacts max 230V, 2A
2000-I/O	4 I/O ports max. 36 V, 100 mA
Hysteresis	0-100%
Reset	Automatic or manual
Contact	Closing or opening software selection

Serial output:	RS232 or RS485, (both in a same output card)
Functions	Only for reading measured values
Addresses	0-127
Number of units	31 units in same RS485
Baud rate	300, 600, 1200, 2400, 4800, 9600, 19200
Protocol	Nokeval SCL
Programming	Front panel keys (4)
Distances	RS232, max 10-20 m RS485, max 1000 m

Special functions:

Display hold	With optional card 2000-I/O, holds display value, output and alarms
Max/min memory	as a standard

General specifications

Input filter	Digital, user selectable
A/D-converter	16 bits (64 000), uni-or bipolar
Temperature drift	0.0004 %/°C with voltage input
Led indicators	Leds 1..4 for alarms, min/max-Leds
Display	6-digit bright red LED digit height 14.5 mm
Power supply	85..240 VAC or 12..32 VDC/24VAC
Front protection	IP65, with gasket
Weight	240 g

Ordering types

2021-REL2-24VDC

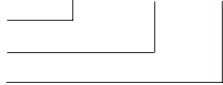
Type 2021	
Alarm card 2000-REL2	
Supply voltage	12..32 VDC, 24VAC
Last parameter always power 24 VDC or 230 VAC	

Order types doesn't contain optional card symbol '2000'. e.g. 2000-REL2 is specified only REL2. Unit may have one input card and two optional cards.

Unit can be updated to other input types only by changing the input card and adding needed option cards. Optional cards are same for all 2000-series units.

Front panel and keys

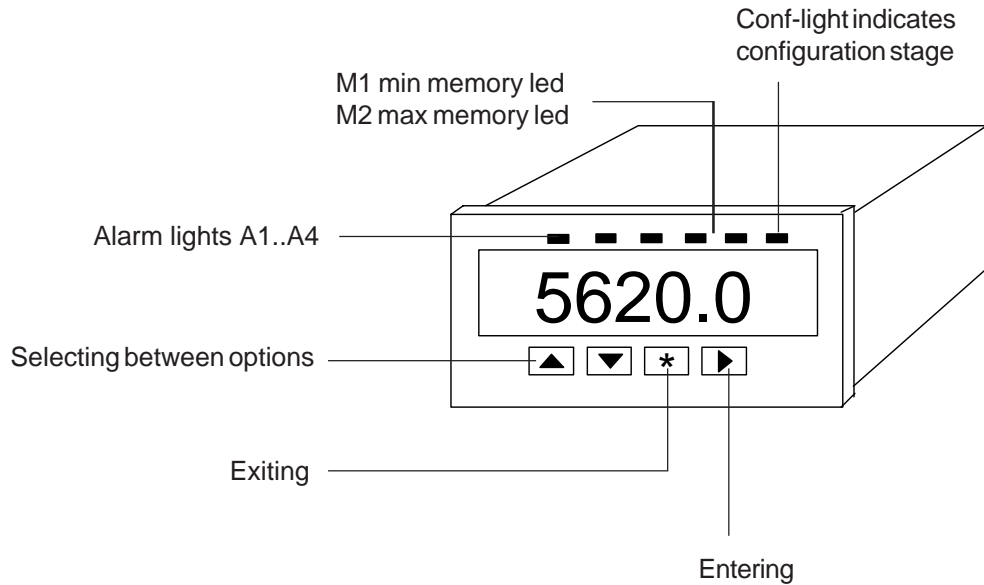

Configuration

You can enter configuration stage by pressing two seconds ▲ and ★ keys at same time. In config state scaling of display, sensor selection and alarm mode are chosen. See closer in chapter programming.

Reset of configuration parameters

Forgotten secret code may be reset by connecting power supply and pressing ▲, ▼ and ►-keys at same time. Then you can enter configuration state entering secret code ▲▲▲▲▲▲ when requested. Change secret code and exit by **SAVE**.

Checking of alarm value

First pressing of ► key shows setpoint of alarm one (A1), correspondingly second pressing shows setpoint of alarm two (A2) etc. Alarm indication light blinks in display informing that alarm level is displayed (if you do not touch keys during 8 seconds display returns to normal state automatically).

Preventing of entering alarms (secret code)

If you have set secret code for alarms you must feed it before you can change alarms (see chapter "settings of secret codes" Page 8).

Change of alarm value

See chapter "Alarm settings by front panel key" Page 8.

Setting of alarm value

You can set alarm value by ▲▼-keys number by number. Setting starts from largest number from left to right. You may go to next number by ►-key. Exit by ★-key.

Number setting

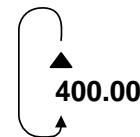

▲▼
Numbers
0...9 and , (decimal)

Configuration

You can enter configuration state by pressing 1 seconds ▲ and ★ keys at same time. By arrow keys you can move upwards and downwards in main menu. By pressing ► key you can enter configuration state at wished point. You can exit to previous state by ★-

key. Hysteresis and alarm mode can be set only in configuration stage. You can cancel changes by selecting text **UnDo** when all is set up, exit by ★ key and when SAVE is displayed, press ► key.

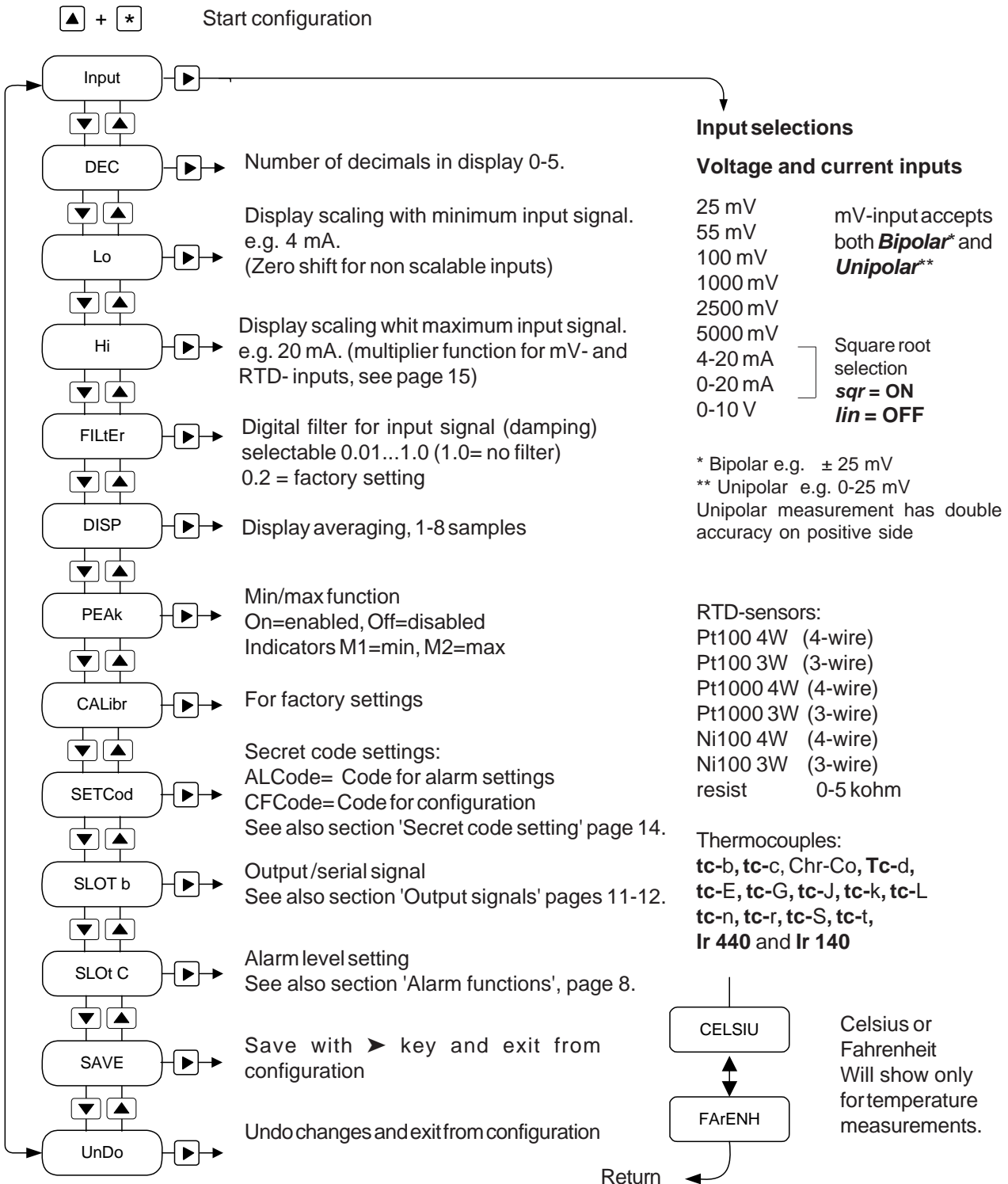

Configuration parameters

Undo, Save (▶)

Exit from configuration state without saving changes (*Undo*) or save and exit (*Save*).

Input selection

Input(▶)	Display	Input type
	25 mV	
	55 mV	mV-input gives possibility
	100 mV	to select Bipolar or
	1000 mV	Unipolar input
	2500 mV	
	5000 mV	mA-input can be
	4-20 mA	Srq = OFF linear
	0-20 mA	Srq = ON squared
	0-10 V	
	IR-140	

0..10 V input setting works also -10..+10 V input range. Bipolar display ± 99999 , Unipolar works only on positive side but gives double resolution compared to bipolar.

RTD sensors (Celsius or Fahrenheit-scaling)

Pt100 4W	(4-wire)
Pt100 3W	(3-wire)
Pt1000 4W	(4-wire)
Pt1000 3W	(3-wire)
Ni100 4W	(4-wire)
Ni100 3W	(3-wire)

Potentiometer

resist 0-5 k Ω 2-wire

Thermocouples (Celsius or Fahrenheit scaling)

tc-b	B-type
tc-c	C-type (former W5)
Chr-Co	Chropel-Coppel Chromel
Tc-d	D-type (former W3)
tc-E	E-type
tc-G	G-type (former W)
tc-J	J-type
tc-k	K-type
tc-L	L-type (former J/DIN)
tc-n	N-type
tc-r	R-type
tc-S	S-type
tc-t	T-type
Ir 140	K-type IR-sensor
Ir 440	K-type IR-sensor

Dec (▶)

Number of decimals in display. Select 0...5 with ▲▼-keys and accept with ★-key.

Lo, Hi (▶)

Display scaling for process inputs. You can set display by **Lo**-value input equal to 4 mA (0 mA or 0 V) and by **Hi**-value equal to input 20 mA(10 V), f.ex. 4 mA=0.0 and 20 mA=100.0.

You may scale also part decimals, f.ex. 500,25, although amount of decimals is set separately.

In mV-ranges **Hi**-setting acts as multiplier, f.ex. range is 25 mV and **Hi**=3,50, display shows 87,5 (25 x 3,5). **Lo** value changes zero level \pm setpoint by mV and temperature sensors. Typical use is eliminating sensor error.

Filter (▶)

Display filtering. Filtering damps restless display. Value setting between 1(min) ...0.010 (max).

1.000 = no filtering

0.200 = normal filtering

e.g. Filter = 0.2. The filtered display value is composed summing 1/5 (20%) the latest measurement result and 4/5 (80%) the previous display value. Filter works liked RC-filter

DISP(▶)

Display update rate 0..7; 0 = display is updated after each measurement (measurement rate of on thermocouples 4 times/second and on the other sensors 12 times/second), 7 = display is updated after every eighth measurement, averaging those eight results.

PEAk(▶)

Min-/ Max- memory selection. On=in use, Off = not in use. Indication lights M1= min. M2= max.

CALibr (▶)

Factory settings

SEtCod (▶)

Secret code settings. See chapter 'Settings of secret codes' page 13.

SLOt b (▶)

Settings of optional cards for slot B. See chapter 'Output signals' pages 11-12.

SLOt C (▶)

Settings of optional cards for slot C (relay- and I/O-cards). See chapter ' Alarms' pages 8-9.

SAVE (▶)

Save changes and exit with **SAVE** and press ▶-key.

Undo (▶)

Return to previous values with **Undo** and ▶-key.

If configuration state contains parameters not mentioned in this manual, you can pass them by arrow keys. Additional parameters will be upgraded to manual periodically.

Alarm functions

General description

Panelmeter 2021 is provided with unexceptionally many versatile alarm functions and therefore it has plenty of basic selections. **When basic selections are done in config state, normal use with front panel keys is very simple.**

Alarm cards:

- REL 2 =** two relays with changeover contacts (grey connectors). You may use two cards (4 relays). Second card is mounted slot B.
- REL 3 =** three relays with closing contacts. Only one card for slot C. Grey connectors.
- 2000-I/O =** four I/O ports (logic alarm, green connector). Only one card in slot C.

Grey connectors are used for power 230 VAC, 2A and green connectors for 36 VDC, 100 mA.

Alarm type, hysteresis, etc. must be done in configuration state.

Removing electronics from case:

Press meter gently behind front plate and draw front frame forwards at upper edge.

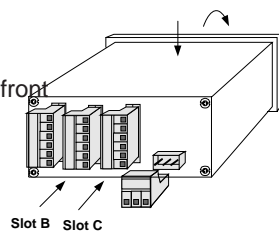

Alarm settings by front panel keys

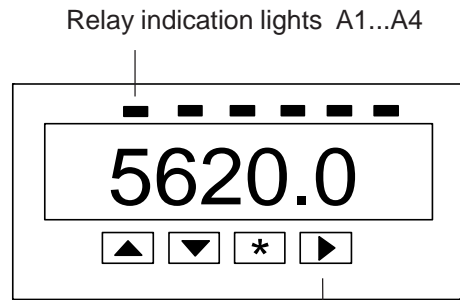

Checking of alarm value

Pressing **▶** once shows setpoint of alarm one (A1), correspondingly second pressing shows setpoint of alarm two (A2) etc. Alarm indication light blinks in display informing that alarm level is displayed (if you do not touch keys during 8 seconds the display returns to normal state automatically).

Preventing of entering alarms (secret code)

If you have set secret code for alarms you must feed it before you can change alarms (see chapter "settings of secret codes" Page 14).

Changing alarm value

First pressing of **▶** key shows setpoint of alarm one (A1), second pressing shows setpoint of alarm two etc. When indication light (A1..A4) blinks you can change alarm level by pressing **▲** or **▼**-key. You can change setpoint of relay in question with keys **▲**, **▼**, **▶**. Accept change by **★**-key (if you do not touch keys during 8 seconds display returns to normal state with automatically and save with same made changes).

Alarm mode, hysteresis and other settings are done in configuration state.

Alarm card connections

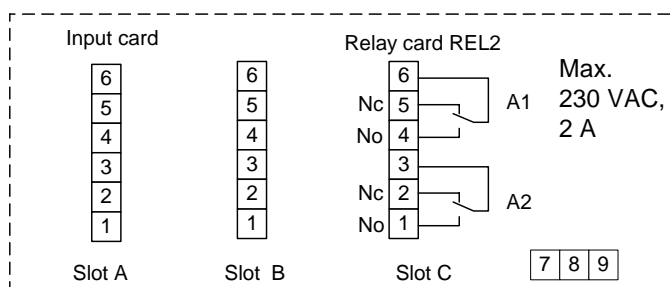

Optional cards are named as Slot C or B

Indicators A1-A4 in front panel

4 logic outputs or inputs

Relay card REL3

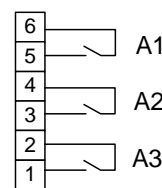

Max. 230 VAC, 2 A

2000-I/O

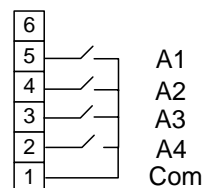

Max. 36 V, 100 mA

Selection of alarm card and relay-function settings

Meter has unexceptionally versatile alarm functions. In initial settings you can select type of alarm card (2, 3 or 4 relays) and into which slot it will be placed. You have to set alarm level, hysteresis etc for every relay. **When initial settings have been made, you can easily set alarm levels by front panel keys** (see chapter "alarm functions" Page 8). You can prevent entering to alarm change state by secret code (see chapter "settings of secret codes", page 14). Alarm card must always be mounted to slot C. If you

need 2 alarm cards (2000-REL2) i.e. 4 changeable relays, second alarm card must mounted to slot B.

Shifting in menu

You shift in menu to next level (to right) in programming stage by ►-key. By ★-key you return to previous level or to main menu. **Example below describes only settings of one relay** (relay numbers 1-4).

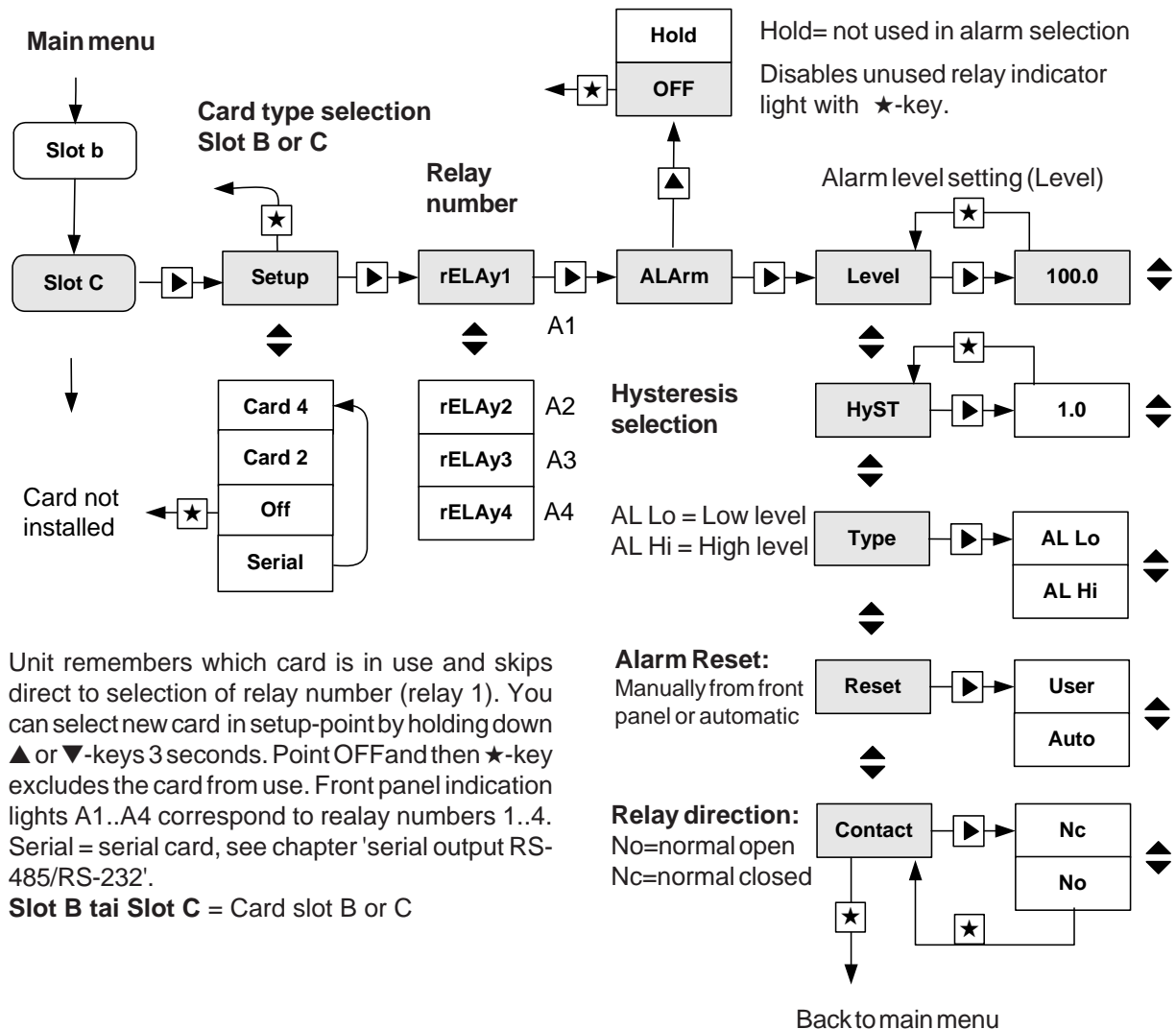

Unit remembers which card is in use and skips direct to selection of relay number (relay 1). You can select new card in setup-point by holding down ▲ or ▼-keys 3 seconds. Point OFF and then ★-key excludes the card from use. Front panel indication lights A1..A4 correspond to relay numbers 1..4. Serial = serial card, see chapter 'serial output RS-485/RS-232'.

Slot B tai Slot C = Card slot B or C

Card type

Card 2 = 2 alarm relays with changeover contacts, 2000-REL2. Second card may be mounted also to slot B, if you need four alarms. Front panel indication lights: Relay 1 = A1, Relay2 = A2 . Relays of slot B use indication lights A3 = relay3 and A4=relay4. If you cannot set four relays, Slot B has not alarm card but some other card.

Card 4 = Card has 3 or 4 relays, 2000-REL3 = 3 relays, logic output 2000-I/O=4 alarms. Front panel indications lights A1...A4 according to relays 1..4=A1..A4. Must always be mounted to slot C.

Next page shows 2 examples of alarm settings.

Examples of alarm settings:

Example 1.

Display 0..100.0 °C and one high alarm (HI) 60°C. Alarm must get off when temperature goes down to 58°C. Display has been ordered with two alarm relays and with two changeover contacts (Relay card REL2). HI level means closing relay indication lamp when temperature exceeds 60°C. Alarm will get off when temperature goes below 58°C and relay will open. 'Alarm-OFF' turns out unused front panel indication lights.

Programming:

Slot C-Setup-Card2-Relay1-Alarm-Level 60.0-Hyst -2.0-Type-AI Hi-Reset-Auto-Contact-No.
Relay2-Alarm-OFF
Relay3-Alarm-OFF
Relay4-Alarm-OFF

Example 2

Display range 0-600°C

1. High level alarm 260°C, opening contact (NC), automatic reset. Hysteresis 1.0°, Use relay 1.
2. Low level 150°C, closing contact (NO), automatic reset, Hysteresis 0.50°C, use relay 2
3. Low level 120°C, manual reset, opening (NC). Manual reset, use relay number 3.

Programming:

Slot C-Setup-Card4-Relay1-Alarm-Level 260-Hyst 1.0-Type AL Hi-Reset Auto-Contact Nc.
Relay2-Alarm-Level 150.0-Hyst 0.5-Type-AI Lo-Reset Auto-Contact no
Relay3-Alarm-Level 120.0-Hyst 1.0-Type-AI Lo-Reset User-Contact nc
Relay4-Alarm-OFF

Alarm reset of relay 3:

Press front panels ►-key three times until indication light A3 turns on. You can reset alarm by *-key. Other relays will reset when alarm turns out.

Description of Type-Reset-Contact-User

Type =selection low (Lo) or high alarm (Hi)
Reset-Auto = Alarm to be reset when value is not at alarm level anymore
Reset-User = Alarm to be reset by front panel
Contact-No = Normally open contacts of relay
Contact-Nc = Normally closed contacts of relay

Display hold by external control (option)

You may lock display by external contact or by logic control. You have to mount 2000-I/O card to slot C. Other I/O-lines may be used for alarm functions. Output, display or alarms do not change state when

display is in hold state. You can turn out the unnecessary indication lights on front panel by selecting OFF-mode for unused relays.

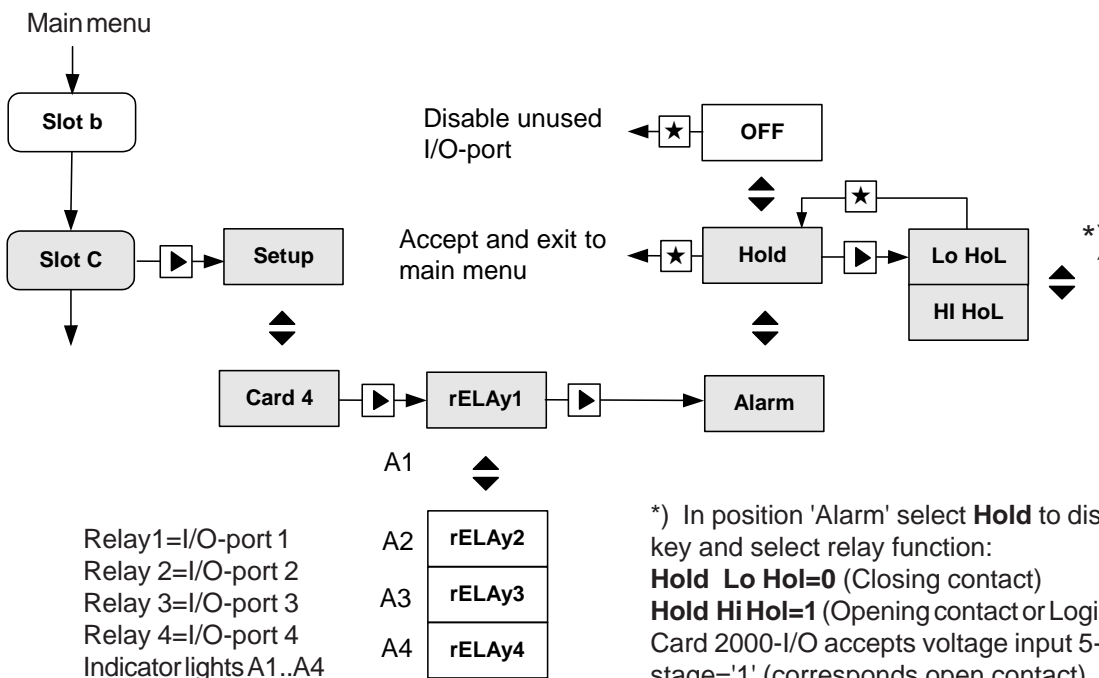

Display hold by external contact

Display hold when contacts are closed

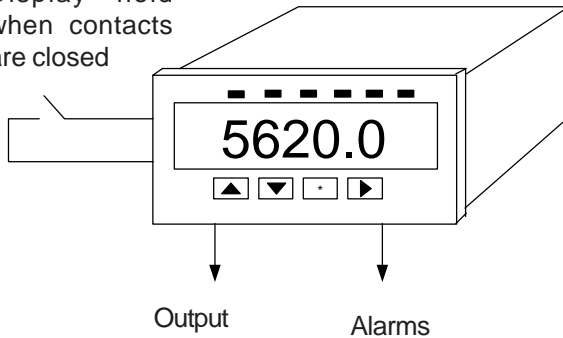

Card 2000-I/O

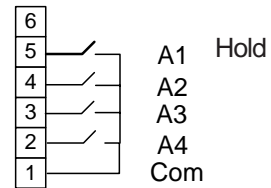

Slots B or C

You can program hold function to input lines 1-4. Closing contact or logic control 5-24 V. Without control input is in measuring state (state 1). Closing contact locks display. You may program other I/O ports for alarm functions.

Output 0/4..20 mA (option)

Meter may be provided with isolated output, ranges 0/4..20 mA or 0..10 V, which are programmable. You can mount output card to slot B or C (default B). Calibration information is saved to card and no calibration is needed in configuration. You need not select

card in programming because meter recognizes the mounted card.

Programming: select slot B in main menu. Press **▶** key. Display shows 4-20. See below description.

Main menu

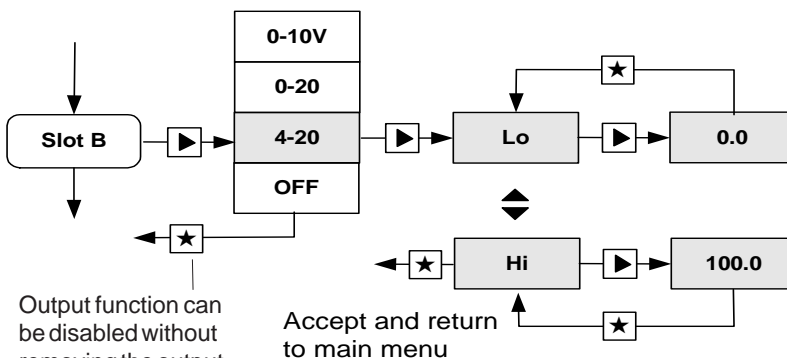

Select output scaling for 0 or 4 mA

Select output scaling for 10 V or 20 mA

Output function can be disabled without removing the output card.

Accept and return to main menu

Output connections

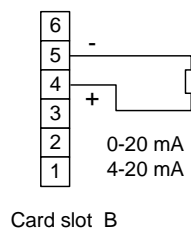
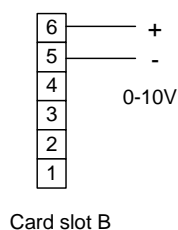

(option)

Passive 2-wire output 4-20 mA

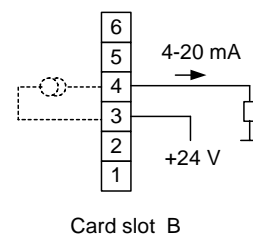

Serial output RS485/RS232 (option)

Meter may be provided with optional serial output and you can read measurements by e.g. PC. Display programming can not be made via serial port. Additional card provides serial signal RS232 and RS485, only one of those can be selected.

Serial signal is isolated from both input signal and power supply. Meters with RS485 can be max. 31 in same loop and longest distance 1000m. RS232 enables only connection of one meter and max. distance 10..20 m.

In config state you can first select card type (serial) mounted to slot B or C and then address and Baud rate. baud rates are: 300, 1200, 2400, 4800, 9600, 19200 and addresses 0...127.

Program remembers card type mounted, if it has been saved by save command when leaving program. In case you can not choose serial card, slot has automatically recognized card (plug and play).

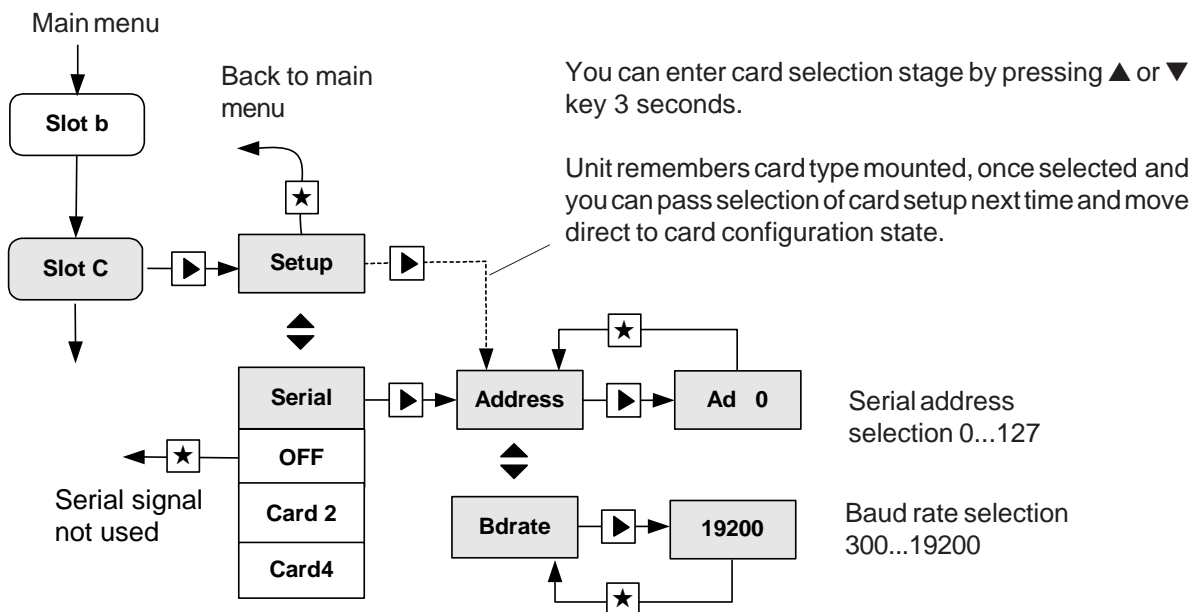

Terminal connections:

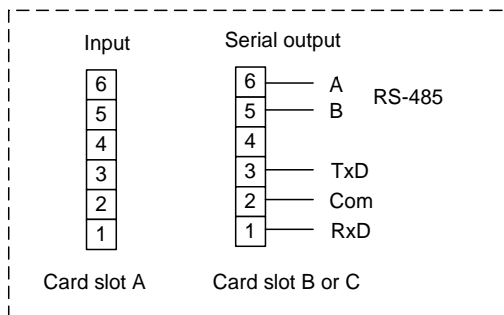

Serial card

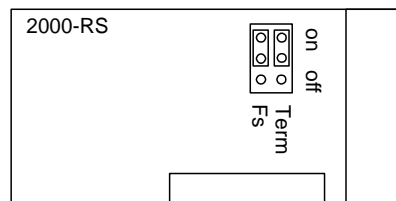

When using serial signal RS485 last unit must be terminated 110 ohm resistor. You can make termination at terminal connectors or connecting jumper J1 to ON position.

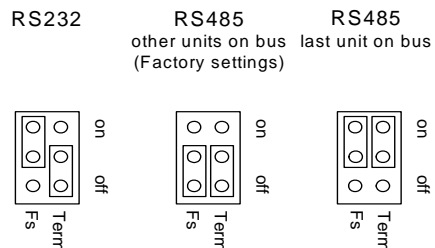

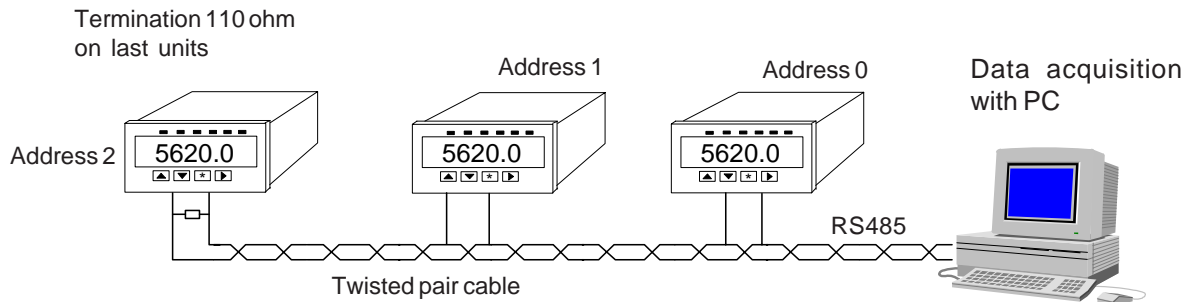

Serial communication

Baud rate: 300, 1200, 2400, 4800, 9600 and 19 200
1 Start, 8 Data and 1 Stop bit, no parity.

Serial protocol (SCL):

MESSAGES: When asking the measurement data from the panelmeter 2021 through the serial port, a command sequence which is in accordance with the SCL protocol is used for the inquiry.

<ADDR+80h>COMMAND STRING<ETX><BCC>

<ADDR>

The first byte character to be sent contains the address of the destination device and at the same time functions as the start indicator of the command. The uppermost bit of this byte is set, in other words 80H (128 in decimal) is added to the address.

COMMAND STRING: When measurement data is requested, the actual command is: MEA CH 1 ? , in which 1 means the channel number. (there is only one channel in the panelmeter 2021 so the number is always 1).

<ETX>

<ETX> mean the end mark of the command, ASCII character 03h.

<BCC>

Finally the checksum is calculated using XOR operation on the byte characters of the actual command including the ETX, excluding ADDR byte. In the example the ASCII codes have been presented in hexadecimal.

e.g.

One wants the measurement result from the display unit address 1. An inquiry is sent:

MEA CH 1 ? (ASCII codes shown for <BCC> calculation)

M E A C H 1 ?<ETX> <BCC>
4Dx45x41x20x43x48x20x31x20x3F x03 = 6F

(XOR operation is presented with a character x) (ASCII code 20h corresponds to space character)

So the following bytes are sent to 2021:

81 4D 45 41 20 43 48 20 31 20 3F 03 6F

RETURN MESSAGE: The answer from the panelmeter 2021 is obtained in the following format:

<ACK>RETURN MESSAGE<ETX><BCC>

<ACK>

The first byte of the answer contains the start of the answer <ACK> (ASCII-code 06h) and the answer itself, endmark <ETX> (ASCII-03h) and the checksum of the answer which is calculated from all the byte characters of the answer including <ACK> and <ETX>. 2021 counts the checksum in which case the receiver does not need necessarily to care about it.

e.g.

e.g. When a measurement result is for example 21.3, it will be obtained from the panelmeter in the following form

<ACK> 2 1 . 3 <ETX> <BCC>
Answer: 06 32 31 2E 33 03 1B

Minimum and maximum value memory

Meter has min. and max. memory as standard. This function must be enabled in config state, parameter **PEAK=ON**.

You can glance values by ►-key. When you press the ► key, the indication lights above display blink on in following order:

1. A1 alarm level
2. A2 alarm level
3. A3 alarm level
4. A4 alarm level
5. **M1 Minimum value memory**
6. **M2 Maximum value memory**
7. None back to measuring stage

Reset memory

You may reset memory when you press ★-key when display shows memory in question, either M1 or M2.

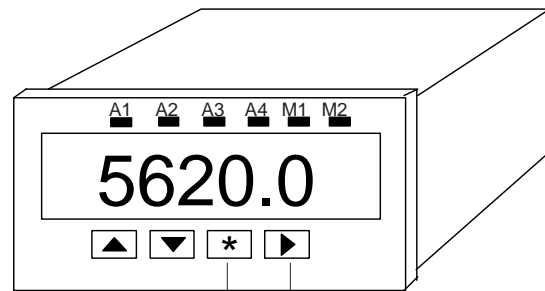

Memory can be viewed with ►-key

Memory can be reset with ★-key when indicator M1 or M2 blinks.

Setting of secret codes (Programming stage/ alarms)

You can enter secret code by pressing six time keys (1-4) in wished order (lines goes forward in display). Setting must be repeated in same order before new setting is accepted.

Example: Press one after another keys ▲▲★►▲▲ and once more ▲▲★►▲▲. You may think the keys as numbers from left to right 1,2,3,4 in order to help

recording and remembering.

e.g. 1 2 3 4

Input code ▲▲★►▲▲ and once more.

Example number value would be 113411.

In menu position **SEtCod** press ► key and move on to selection stage.

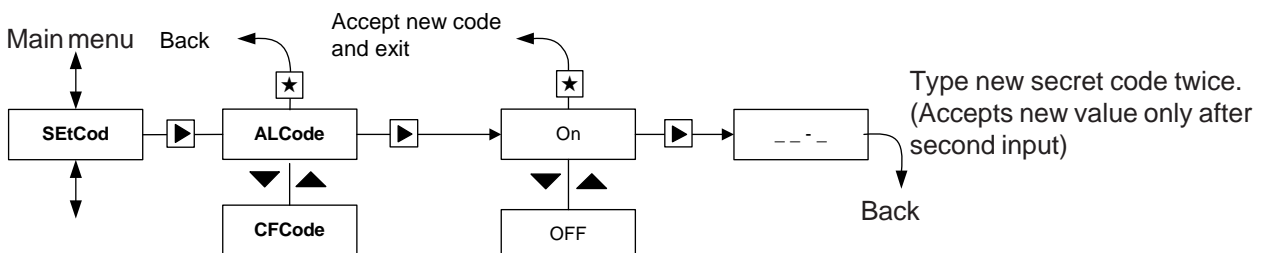

Select secret code to set:
CFCod config
ALCode for alarm levels

Secret code:
 ON = enable
 OFF = disable (default)

Potentiometrin skaalaus opetustoiminnalla

Näytön skaalaus potentiometritulolle suoritetaan ohjelmointivalikosta asetuksilla **Lo** ja **Hi**, kun potentiometrin asento seuraavasti:

Poista ensin jo olemassa olevat asetukset, asettelemalla **Lo**:n arvoksi "0" ja **Hi**:n arvoksi "1" (tehdasasetukset). Tämän jälkeen aseta potentiometri haluttuun ala-asentoon ja kirjaa ylös näytön näyttämä (X_1) ja samoin vastaavasti haluttu yläasentoon vastaava näytön näyttämä (X_2). Seuraavassa laskutoimituksessa Y_1 vastaa uutta haluttua näytön näyttämää (esim. 30.0) kohdassa X_1 ja vastaavasti Y_2 kohdan X_2 haluttua näyttämää (esim. 150.0).

Ensin lasketaan **Hi** asetuksen uusi arvo: $Hi = (Y_2 - Y_1) / (X_2 - X_1)$

Tämän jälkeen lasketaan **Lo** asetuksen uusi arvo: $Lo = Y_1 - Hi * X_1$

P100 anturin ja mittarin kalibrointi vertailulämpötilassa

Suurta tarkkuutta vaativissa mittauksissa, mittarin ja anturin virhe voidaan poistaa sijoittamalla Pt100-anturi vertailulämpötilaan ja korjaamalla näyttämävirhe ohjelmointitilassa Lo ja Hi asetuksilla. Kalibrointi tehdään kahdessa eri lämpötilassa, toinen 0 °C ja toinen korkeammassa lämpötilassa esim. 120°C.

Päävalikko

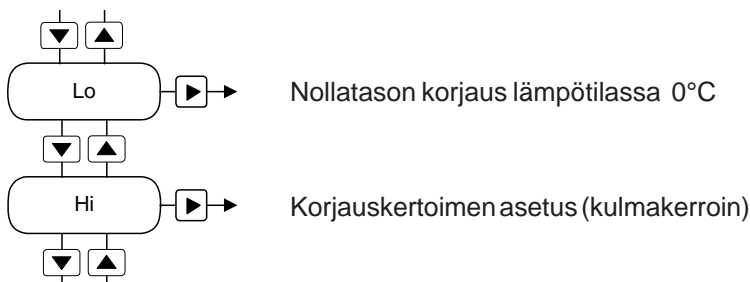

Kalibrointimenettely:

1. Nollatason kalibrointi

Sijoita anturi lämpöhauteeseen 0.0°C. Lue näytön arvo. Jos mittarin näyttämä poikkeaa hauteen lämpötilasta, korjaa näyttö vastaamaan hauteen lämpötilaa syöttämällä erolämpötila vastakkaismerkkisenä päävalikon kohtaan **LO** (nollan siirto).

Esimerkki: Mittarin näyttämä +0.1°C kun hauteessa 0,0°C. Syötä LO-arvoksi -0.1°C. Mittari siirtää nyt näyttämää -0.1°C ja näyttö korjaantuu arvoon 0,0°C.

2. Korkeamman lämpötilan kalibrointi

Sijoita anturi haluttuun lämpötilaan, esim. 120°C. Lue näyttöarvo.

Laske korjauskerroin seuraavasti: **hauteen lämpötila / näyttöarvolla = korjauskerroin**. Syötä laskettu korjauskerroin päävalikossa kohtaan **HI**.

Esimerkki: Jos mittarin näyttöarvo on 120,3°C, kun anturi on sijoitettu 120.1°C lämpöhauteeseen, korjauskerroin on 120.1°C/120,3°C=0,99833. Mittari kertoo nyt mittauseron annetulla HI-arvolla poistaen anturin ja mittarin virheen.

Terminal connections

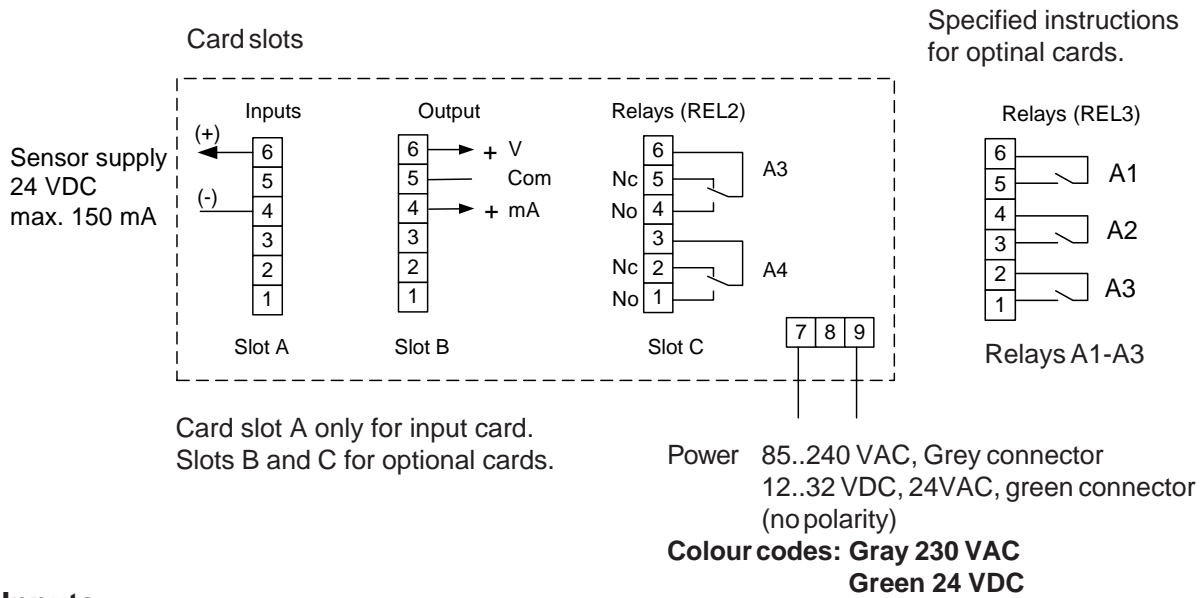

Inputs:

2-wire 4..20 mA

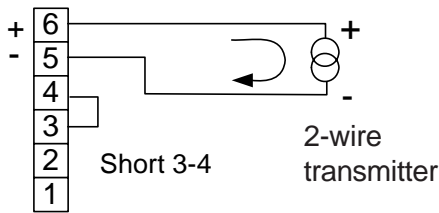

Current input 0/4..20 mA (active transmitter)

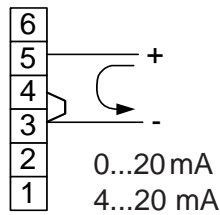

Pt100 3- and 4-wire

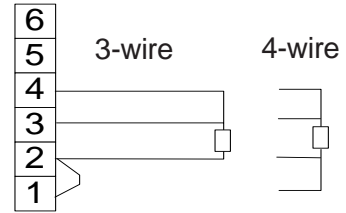

Sensor supply 24 VDC, max 150 mA

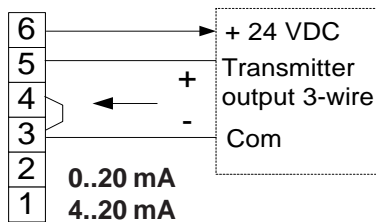

Thermocouples and mV

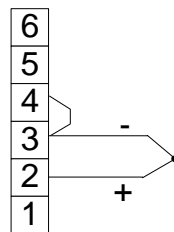

Thermocouples, mV,
25, 55, 100, 1000 mV, 2,5 V ja 5 V

Input selection in configuration mode

Potentiometer 0..5 kΩ

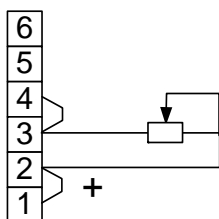

Voltage 0..10 V and -10..+10 V

0..10 V and -10..+10 V

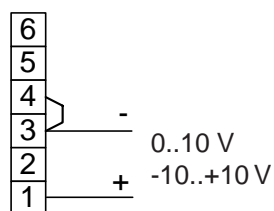

0..10 V input requires moving jumper J1 to position 1-2, for other inputs select 2-3.

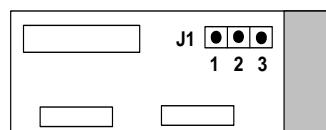

Input card 2021-MU

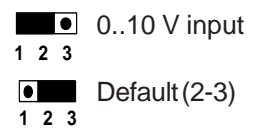

Panelmeter 2000 construction

The 2000 series panelmeters are modular and easy to assemble. According to customers wishes. The basic construction consists of mother board with three slots, A, B and C. Slot A determines meter type and provides always input signal. Slot B and C are interchangeable. As factory delivery input signal is always installed into slot A, mA output into slot B and alarms into slot C. In case of f.ex 4 alarms and relay card with 2 change-over contacts (2 + 2 relays) are used, you must place

second relay card into slot B. The slot B is now usable for other optional outputs.

You can have different types of meters by only changing the input card in slot A. Data sheet of each type of meter dictates the possible combinations. Recalibration of card is not needed; only scaling and other settings must be set by front panel keys.

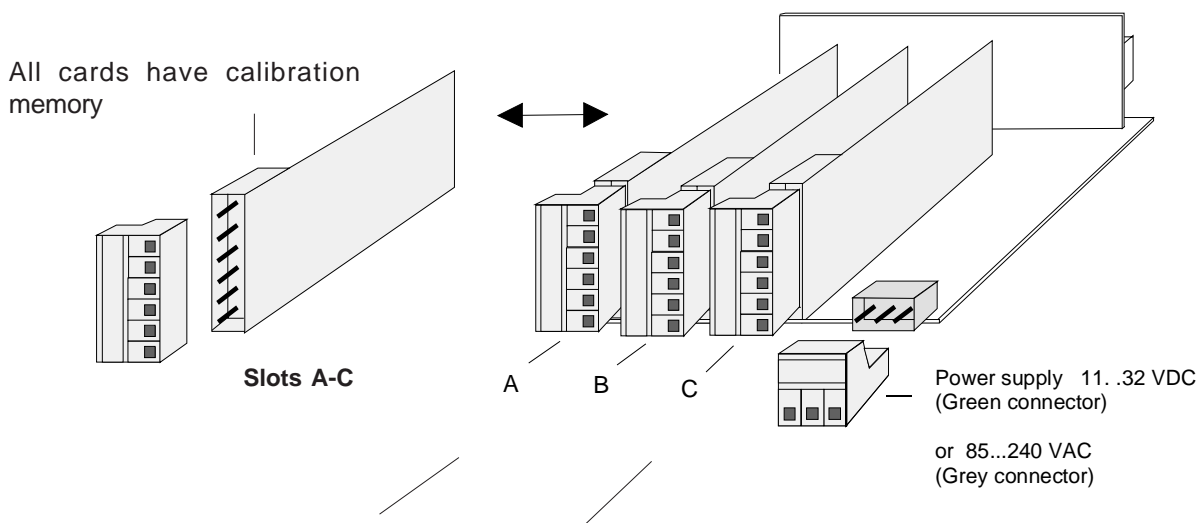

Changing meter type:

Input card is placed always in slot A. By changing input card you can get an other type of meter. You can change meter with pulse input to meter with current input, thermocouple, strain gage etc.

Additional slots:

Additional cards provide output 4..20 mA, alarms, serial interface, BCD output etc. Meter data sheet dictates possible combinations. Grey connectors allow line voltage 110..240 VAC (relay contacts).

Power supply:

There are two different mother boards, for power supply 85..240 VAC and 12..32 VDC. The latter mother board accepts 24 VAC.

Removing meter from case:

Loose connectors and front panel, draw meter out from front. You may remove mother board from rear by opening four screws in corners of case.

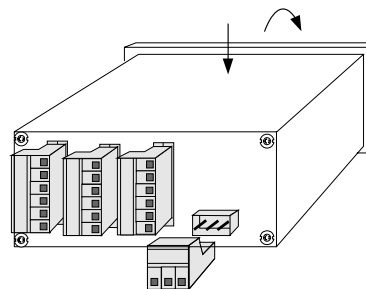

Press gently case behind front panel and draw frame outwards gripping upper part of frame.

Modular indicator series 2000

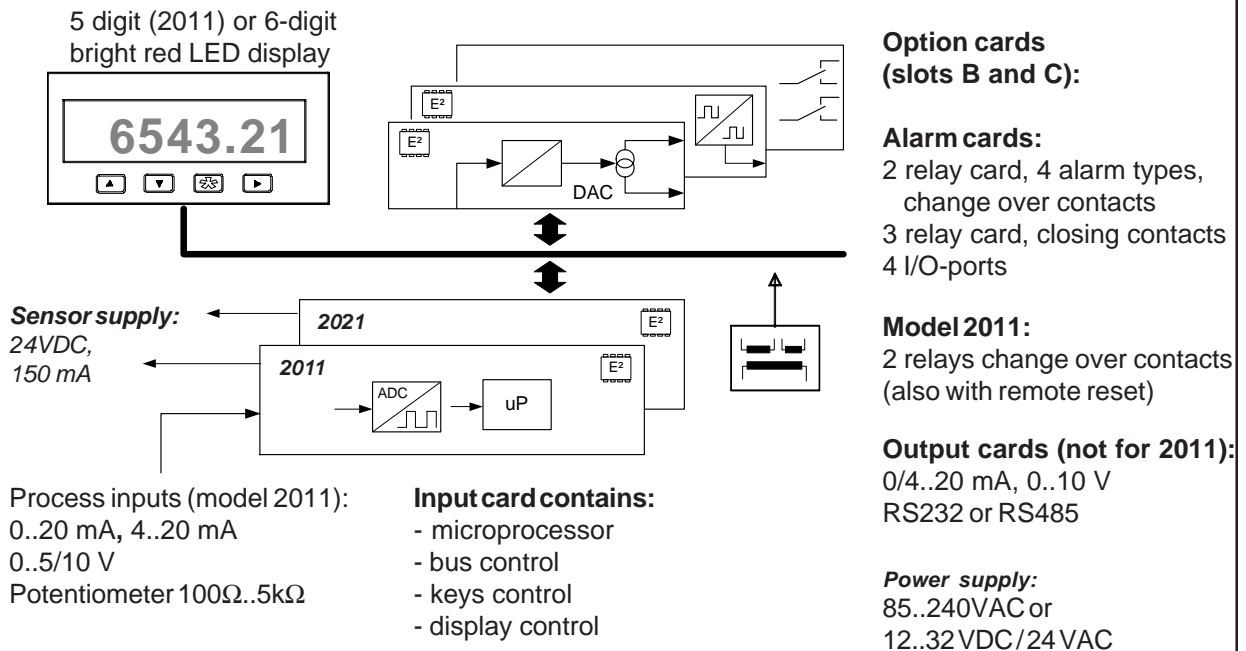

Model 2021 contains also process inputs but it can measure RTD-sensors and thermocouples. 2021 has very accurate and fast A/D-converter (16 bit 1/64 000).

2000 series input and option cards:

2011-IN	Process input	2000-BASE	Base card with power supply
2021-MU	Multi input	2000-REL2	Alarm card, NO/NC
2031-IR	Infrared sensor input	2000-REL3	Alarm card, Closing contacts
2041-STG	Strain gage measurement	2000-OUT	Output card, U and I
2051-Hz	Scaleable frequency indicator	2000-RS	Serial output RS232 or RS485
2061-CNT	Counter input (max 5 kHz)	2000-I/O	4 pcs input /output ports (60 V / 100 mA)
2066-TIM	Timer function, s/min/h ext.		
2071-RS	Serial input RS232 / RS485		
2081-BCD	BCD-, Gray- binary code input (1-5 digits)		

Manufacturer:

Nokeval Oy

*Yrittäjäkatu 12
37100 NOKIA
FINLAND*

*Tel. +358 (0)3 342 4800
Fax.+358 (0)3 342 2066
www.nokeval.com*